

REVISION RECORD  
 REV. No. MADE BY APPROVED BY DESCRIPTION

Item Number	Document Number	Title	Material	Quantity
1	SBM-01-00		CAST IRON	2
2	SBM-02-00		CAST IRON	1
3	SBM-03-00		CAST IRON	1
4	SBM-04-00		CAST IRON	1
5	SBM-05-00		CAST IRON	2
6	SBM-06-00		CAST IRON	1
7	SBM-07-00		CAST IRON	1
8	SBM-08-00		CAST IRON	1
9	SBM-09-00		CAST IRON	1
10	SBM-00-00		CAST IRON	1
11	SBM-11-00		CAST IRON	1
12	SBM-12-00		CAST IRON	1
13	SBM-13-00		CAST IRON	1

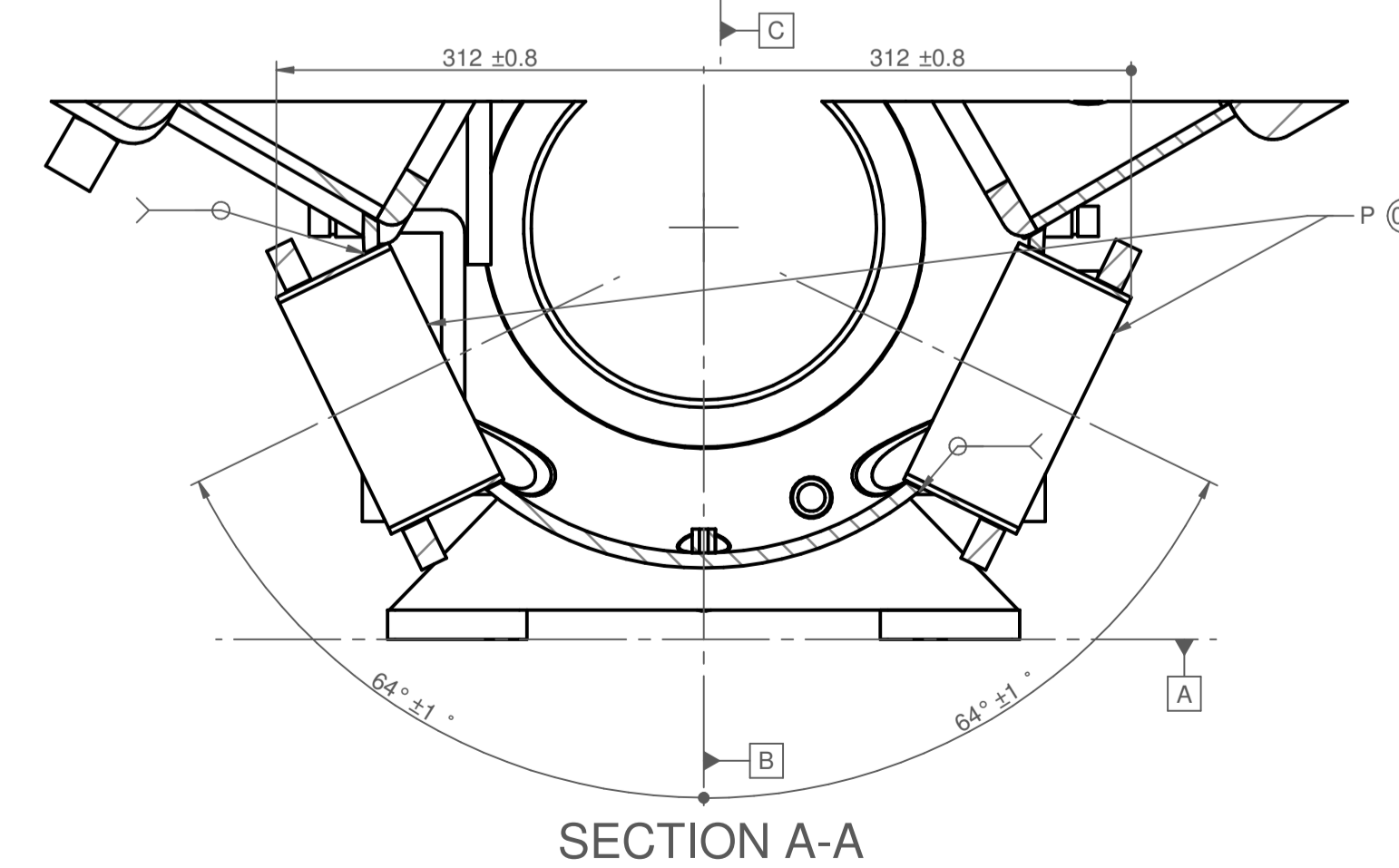
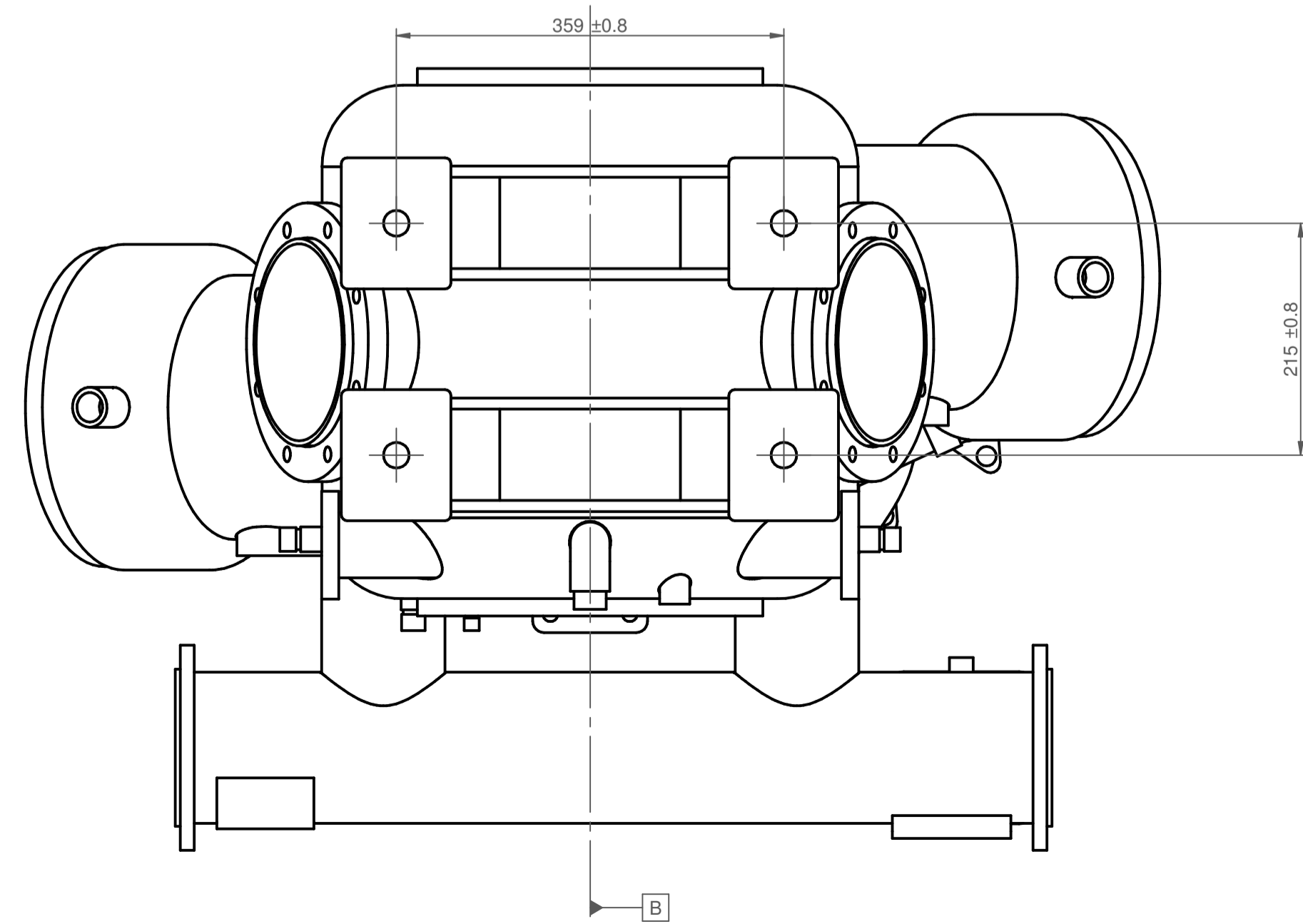
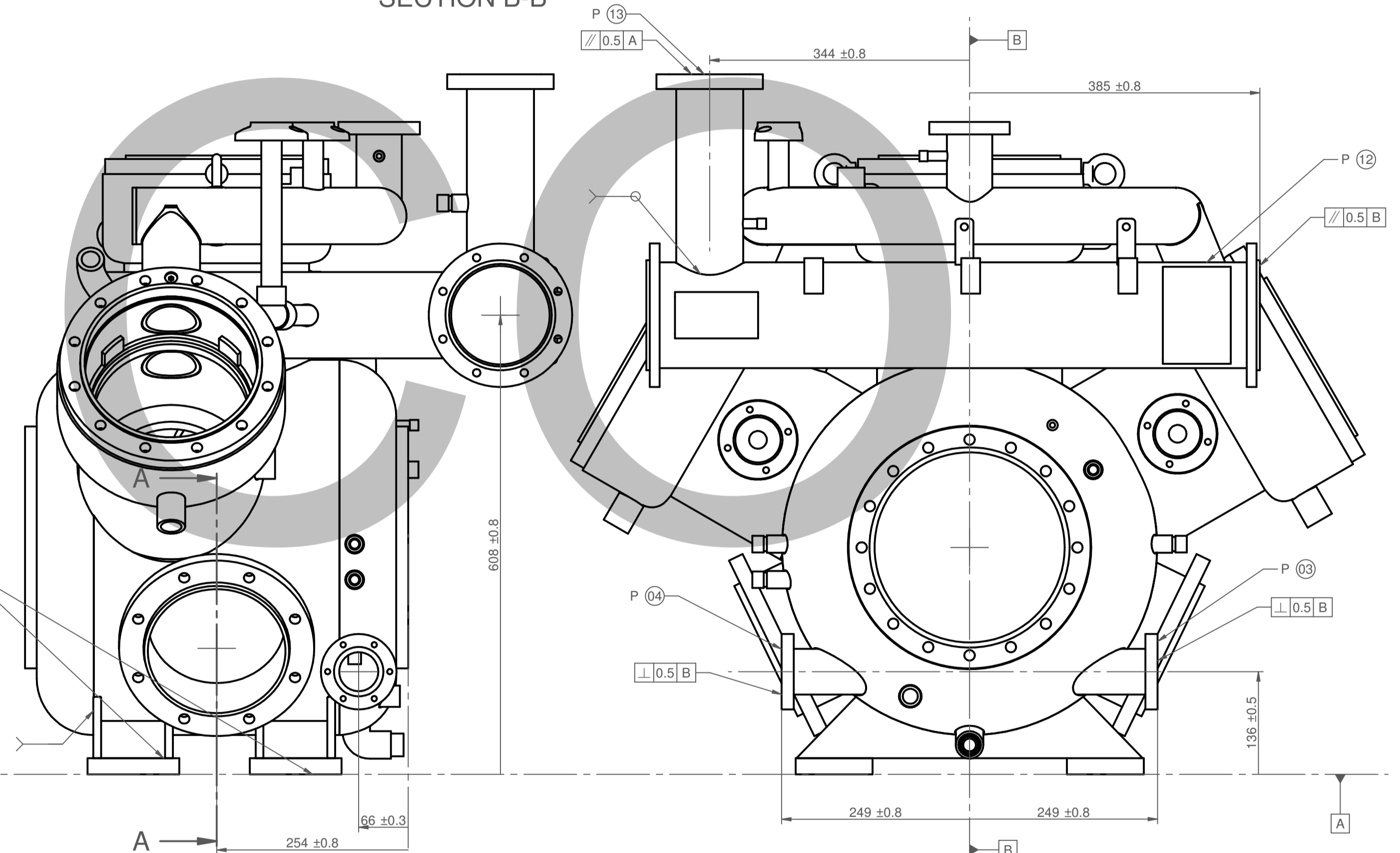
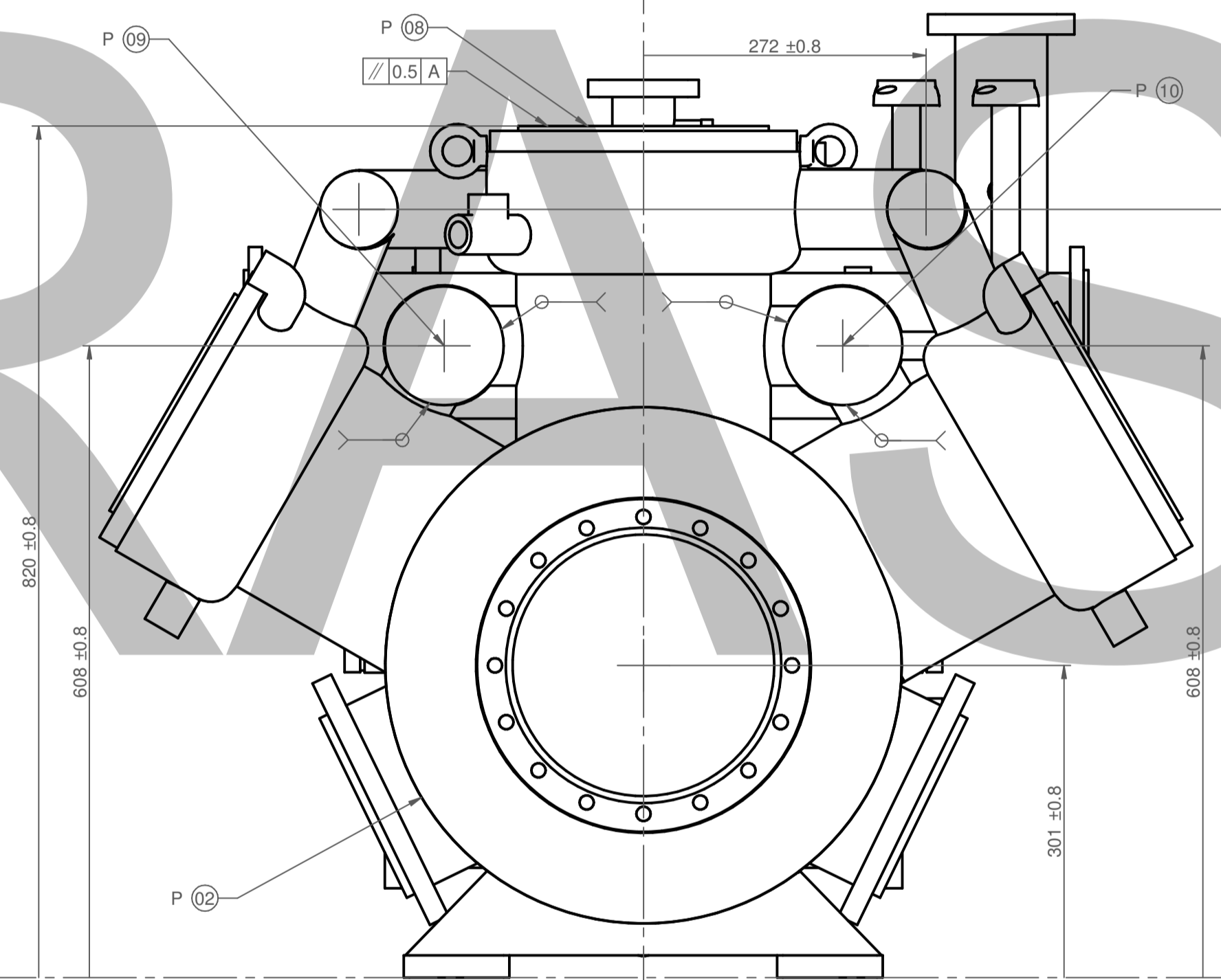
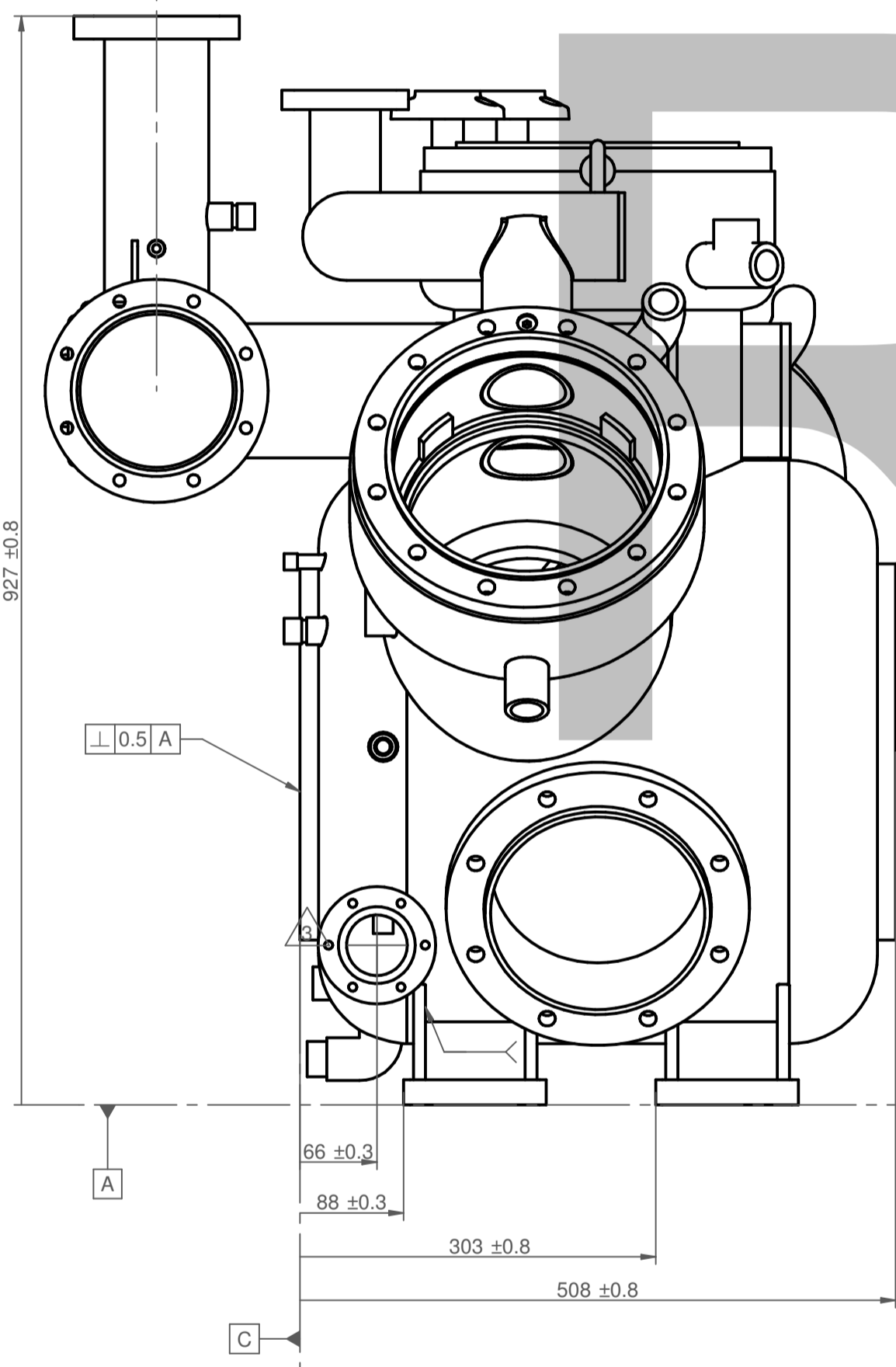
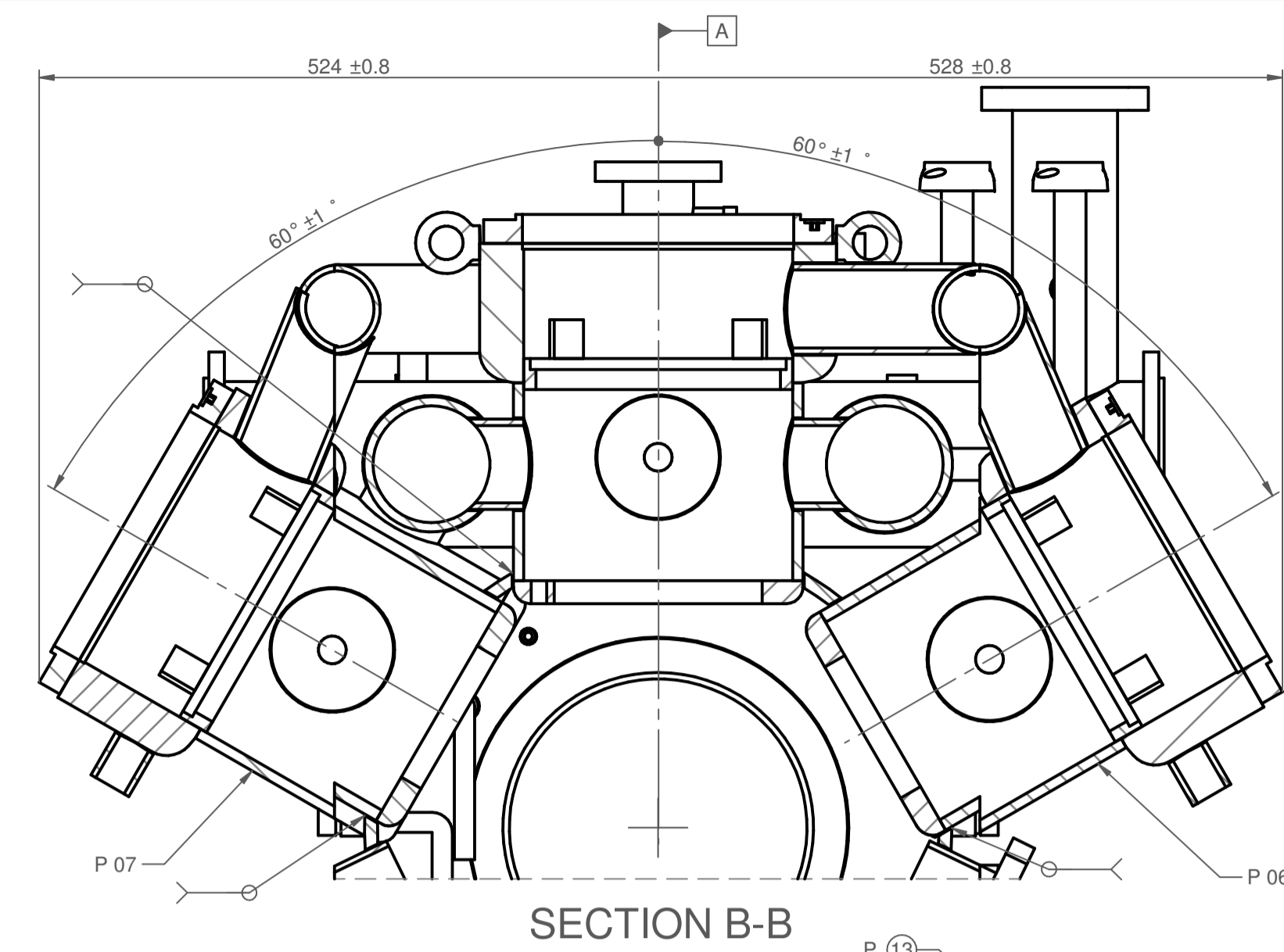
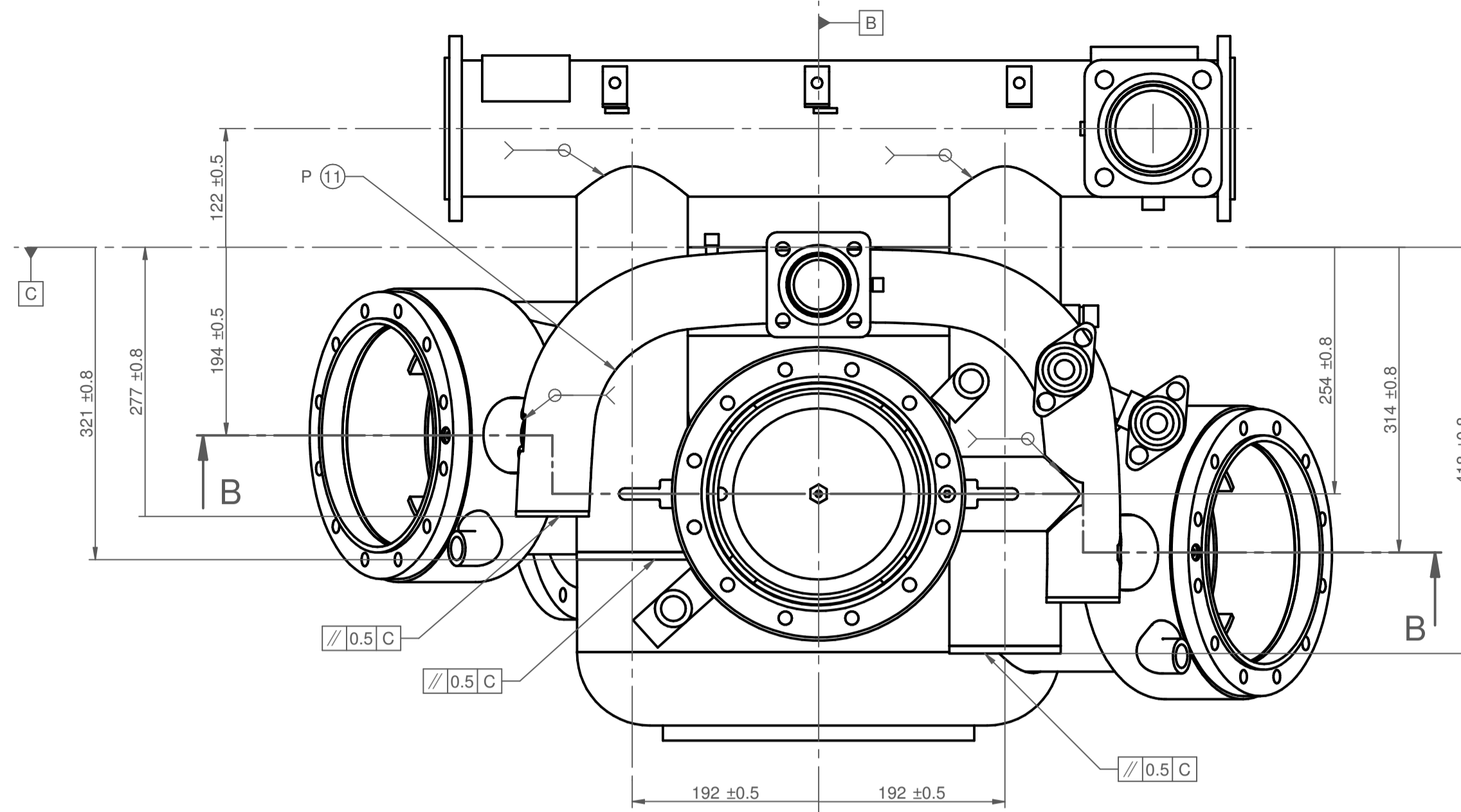

NOTES:  
 1. ALL DIMENSIONS IN MM UNLESS OTHERWISE SPECIFIED  
 2. DO NOT SCALE THE DRAWING  
 3. THE ASSEMBLY HAS BEEN DIVIDED INTO 13 SUB ASSEMBLIES ARRANGED IN ASSEMBLY SEQUENCE. FOR DETAILED SUB-ASSEMBLY DRAWINGS REFER TO SHEET 2-14 OF 14.  
 4. FOR ASSEMBLY WELDING FOLLOW WELDING INSTRUCTIONS/SYMBOLS.  
 5. ASK IF IN DOUBT.

PROPRIETARY & CONFIDENTIALITY NOTICE:  
 THIS DRAWING IS A PROPERTY OF RASCO. IT SHALL NOT BE COPIED/TRANSMITTED/CIRCULATED IN ANY FORM WHETHER PHYSICAL OR ELECTRONIC. DEPICTION/USE OR REVELATION OF ANY DATA CONTAINED IN THE DRAWING SHALL BE MADE AFTER PERMISSION FROM CONCERNED AUTHORITIES.

NAME	DATE	RASCO	
DRAWN		TITLE	SAMPLE ASSY. DRAWING
CHECKED		SIZE	A1
ENG APPR		DWG NO	SAMPLE ASSY. DRAWING
MGR APPR		SCALE	1:5
UNLESS OTHERWISE SPECIFIED DIMENSIONS ARE IN MILLIMETERS ANGLES ±XX° 2 PL ±XXX 3 PL ±XXXX		WEIGHT	SHEET 1 OF 14